

ALTI2

Overview

The ALTI2 is a Digital Recording Altimeter that enables you to store and retrieve an altitude profile of your model or activity for later download and analysis. ALTI2 measures changes in pressure, at a pre-determined sampling rate that is selected by the user, and stores the results in its on-board memory.

The data is then downloaded to your PC using our ALTI2 Analysis Software which then converts the pressure readings to altitude. There are 4 sampling rates possible as shipped (0.1, 0.2, 0.5, 1.0 seconds) and, with a minor modification a 2nd set of different rates (0.2, 1.0, 2.0 and 6.0 seconds) is available.

The sampling rate is selected via a small DIP switch located just inside the open end of the ALTI2 case. The maximum memory capacity of ALTI2 is 2hours 16 minutes when a 1-second sampling rate has been selected. When a 6-second sampling rate is used, the capacity is more than 13 hours, and when using the ALTI2 BF version more than 2 days (52 hours) of storage are available!

Device memory area is separated into individual data recording sessions-flights which are created automatically each time device is switched ON. Each flight is independent in length, storage period and altitude data. As an example: You can have one session of your trip to the flying field, then several sessions of flights, and another session of your return trip home. Once at home (or if you have a notebook PC) you can download ALTI2 sessions to your PC for processing and analysis.

Technical Specification

Standard & BF

- Dimension L38xH13xW18 mm (L1.49xH0.5xW0.7 inch.)
- Weight 9g incl. 150mm JR/Graupner cable
- Sampling rates. Using DIP switch you can choose requested sampling rate.

Standard: 0.1sec (14min), 0.2sec (28min), 0.5sec (1h:8min) and 1.0sec (2h:16min). There is also available second set of sampling rates 0.2, 1.0, 2.0 (4h:32min) and 6.0sec (19h:36min) but needs some tiny hardware hack. See HW hack

BF has four times bigger memory: 0.1sec (45min), 0.2sec (1h:52 min), 0.5sec (4h:32min), 1.0sec (9h:4min). There is also available second set of sampling rates 0.2, 1.0, 2.0 (18h:8min) and 6.0sec (54h:30min) but needs some tiny hardware hack. See HW hack

- Total memory capacity 8 180 records in Standard version and 32 720 records in BF version
- Power 4.4-9.6 Volts DC
- Current consumption 15mA
- Resolution 0.5m (don't mix with accuracy)
- Maximum altitude (recommended) 3000 m (9.843 ft). This limit is relative i.e. if you switch ON in 2000m you can go up to 5000m. Above relative 3000m limit A2 also works and measures, but accuracy of used pressure/altitude equation is already questionable. See also Q&A.
- Number of Flights (ON/OFF cycles), not limited

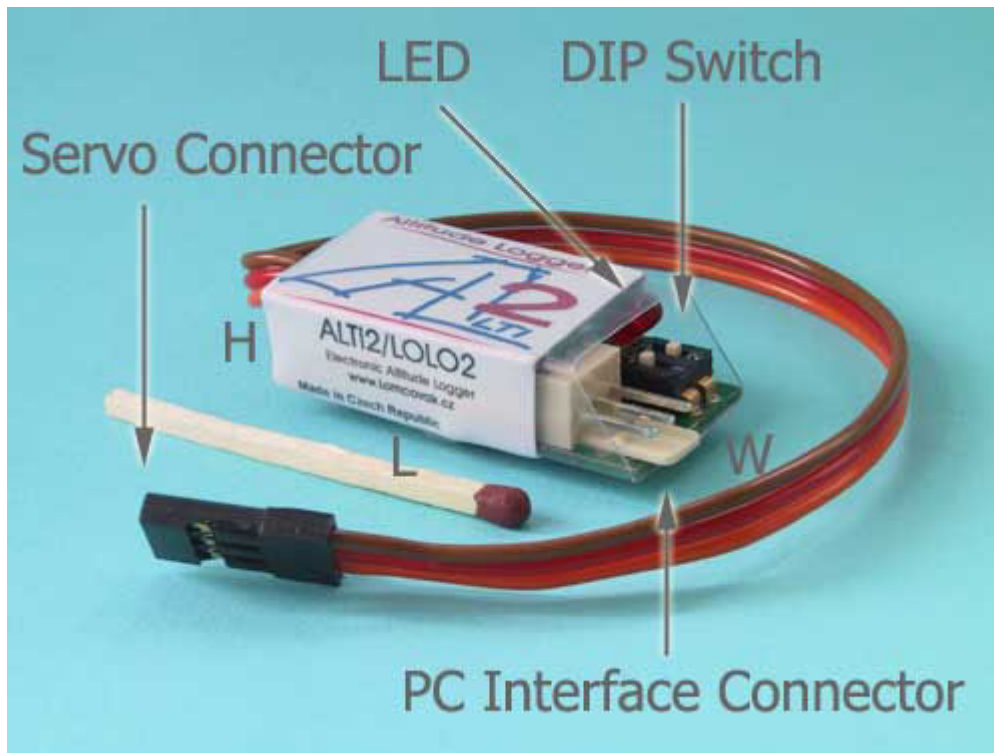

Alti2

Installation

Alti2 is very small device and allows you to use it nearly in all applications. It uses very precise atmospheric air pressure sensor, you should let surrounding atmosphere to reach your A2. I use it in F3B/F3F models where canopy, wing and fuselage fits very tight, but are not evidently hermetic while A2 works.

Respecting A2 is actually air pressure logger (formula calculating altitude is in your PC) you should consider placing it in environment where "sucking" or "pressure" effects are minimal. Otherwise results can be dependent forexample on speed of your aircraft. Always think twice and take in account this facts especially when evaluating some strange looking altitude log results.

It's digital device, microprocessor is inside (and X-tal), you should avoid to place it just no-gap sideaway of other RC components (receiver, servos, gyros etc.). In F3X machines there is never plenty of room anyhow I never experinced any problem.

Some other hints for A2 installation:

- Install ALTi2 as far as possible from high current wires
- Power spikes may affect altitude readings and proper operation of the ALTi2 is guaranteed only when supplied with power free from any interference
- If the power source of your model is not appropriate for the altimeter please use a separate power source. A good choice is a 4.8V 110mAh capacity pack, which should be sufficient for 5 hours of continuous operation.

If you want to have full controll of your A2 you have to connect it to free receiver (Rx) output/channel which you will control using transmitter (Tx). It allows you to:

- switch it ON (from standby mode)
- place Markers M1,M2,...Mx) in altitude log
- switch it OFF to spare A2 memory

If you will connect A2 to standalone DC source (4.4-9.6V) i.e. no signal from Rx*, it will start logging automatically after 120sec. It can be used for outdoor activities etc.

*If you will connect A2 to any Rx output (although NOT controlled) it will NOT start log automatically, there is always on Rx output some signal. A2 will be in stand by mode waiting for signal change from Tx. If you don't want to use standalone DC source (you want to power A2 from Rx) don't connect signal pin (orange color on provided JR /Graupner connector) of A2 and signal output of your Rx.

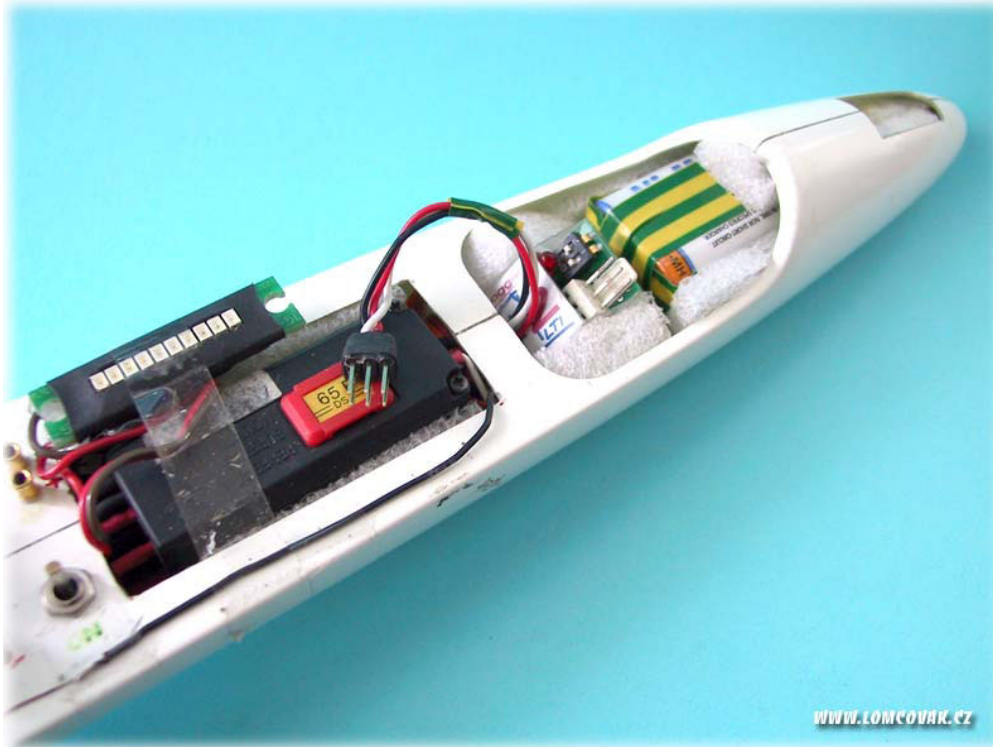

A2 installation in F3B BigSting



A2 installation in F3B Caracho 3.1 Plus

Clearing Memory

Before first use clear A2 memory. Same procedure you have to do always when you want to clear (empty) your A2 memory. You will clear all recorded logs.

- Disconnect A2 from power (switch OFF your Rx)
- Connect interface cable to A2
- Keep pressed Clear button on interface cable
- Connect A2 to power (switch ON your Rx)
- After 1-2sec LED wil start to blink, A2 memory is cleared, release Clear button
- Disconnect A2 from power (switch OFF your Rx) and interface cable, A2 is ready for new logs

Logging (Three Operation Modes)

ALTi2 is operable in 3 modes:

- Transmitter Controlled – ALTi2 is connected to your Rx with a Signal lead and, using your transmitter, you can initiate data logging upon request, at any time, from your transmitter (using any channel or switch/button). You can also enter signal input Markers that will "mark" that point in the data as a significant event. A Marker is initiated by the same stick or switch/button movement you use to start logging. The Markers appear in the ALTi Analysis Software as points M1, M2....Mx.

For controlling A2 there are two levels of Tx signal necessary. It corresponds to servo deflection -100% and +100% (MIN-MAX). Don't let controlled channel to be somewhere in between of these two levels, undefined results can occur.

After switching Rx ON, LED on A2 is indicating channel status; LED is slowly FLASHING-channel is in MIN (-100%) position, LED is ON-channel is in MAX position. You can reverse it using your transmitter (Tx) if it has such functionality.

For altitude logging start you need to switch over channel status (MIN-MAX-MIN or MAX-MIN) using any controller on your transmitter (stick, switch, potentiometer, button). Allow at least 1sec interval between position MIN-MAX-MIN (keeping stick, switch on transmitter in position MAX 1sec).

When A2 is logging altitude you will see very short flash (0.25sec) of LED in interval of choosen sampling rate. Every next channel full deflection (MAX, +100%) logs Markers (M1, M2,...Mx) in your altitude log. It allows you to see them in provided software after download for later analysis purpose.

You can stop logging also using Tx. If you keep controlled channel status in MAX(+100%) for more than 6sec A2 will stop logging. This feature is just for preserving your memory in A2. LED is ON (no blinking) in this hybernated status (its NOT stand by status). You can NOT switch ON (to logging mode) A2 from this status using Tx again. You have to switch power for A2 OFF and ON.

- Transmitter Independent - ALTi2 is connected to your Rx with the Signal lead (Orange lead on JR/Graupner connector) deactivated and, after a 120 second initialization phase, starts automatic data logging at the sampling rate specified and there are no data "Markers".
 - Non-R/C – ALTi2 is NOT connected to an Rx but is instead connected only to an appropriate power-source and will respond the same as if installed Transmitter Independent. The difference being that there is no Signal lead to be deactivated.

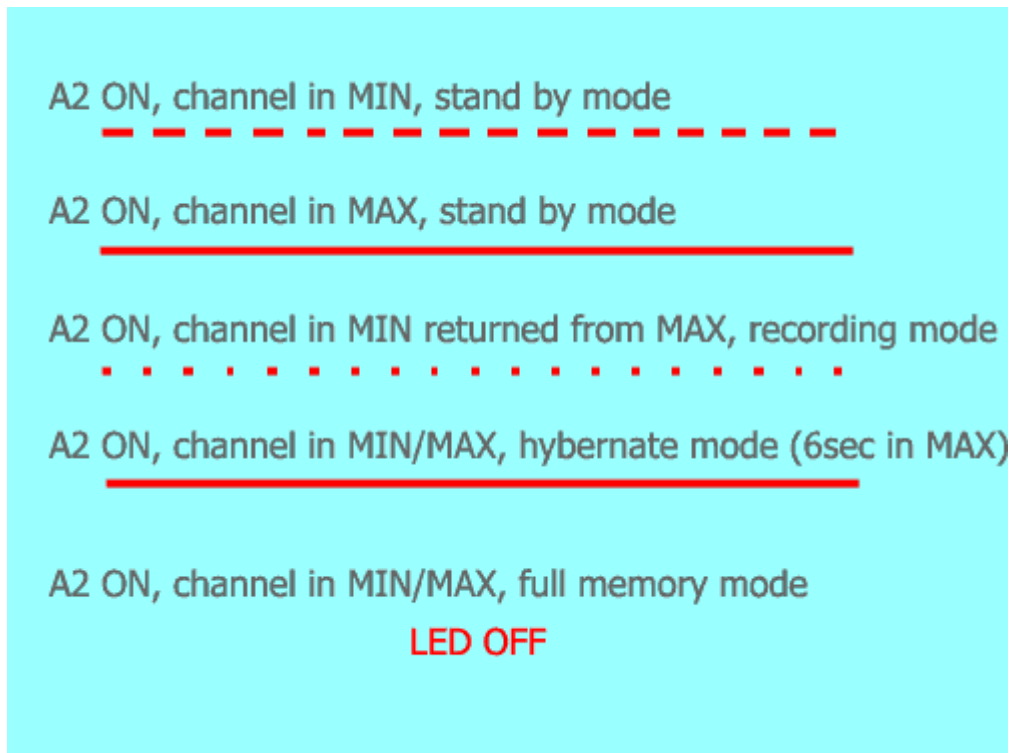

A2 LED status

Downloading Data

There are altitude logs in A2 memory which you would like to analyse. After you installed software in your PC you can download data.

- Switch OFF power for A2
- Run programm Alti.exe
- Select Data, Read Data (CTRL+R), window "Waiting for Data" pops up.
- Connect Interface cable and switch ON power for A2, download starts automatically (LED of A2 is ON during sending data to PC, OFF when all data are sent)
 - If there are more than one Flights (Cycle A2 power ON/OFF is treated as ONE flight) you will be asked if you want to save it as one Session (more Flights in one Session) or every single Flight as one Session (one Flight in one Session). Select OK, your data are displayed.
 - Download is finished, disconnect A2 from interface cable and power
 - Analyse your Data

Analysis Software Instructions

You installed software on your PC. Check in DATA-SETTINGS which serial port you use. Don't change default values in SETUP 19200,8,NONE,1,NONE. There is also available proved USB/RS 232 convertor which I warrant will work with your ONLY USB PC. This software should allow you to analyse any flight logged by your A2. I'm convinced you won't need any other tool to understand what's going on up there. Well, let's dig in and I will try to give you rough idea about some neat features of this package.

Picture 1 explanation

Every download session is called-Module, every flight/log in Module is called-Block. All they have by default increasing numbering, Module1, Module2, inside in Module1 there is Block1, Block2, Block3 etc. Usually I rename (click and drag) Module to named pilot and Blocks I name as flights or tasks (in F3B you can call them 1A,1B, 1C etc.) see 1 and 2. After downloading data (Ctrl+R) I renamed Modules and Blocks as mentioned before.

First pilot-Vitek, Second -Jirka, third-Roman and fourth-Jindra. After renaming Modules and Blocks, save file as librec see **3**, your data are valuable therefore don't rely to Windows and every work save regulary. On the bottom side of working area there two tabs see **5**. Info and Graph. Info shows any comments and if any flight is chosen in left part, Info also shows some key data about flight. Icon **4** allows you basic setup of programm which is valid for communication and all downloads.

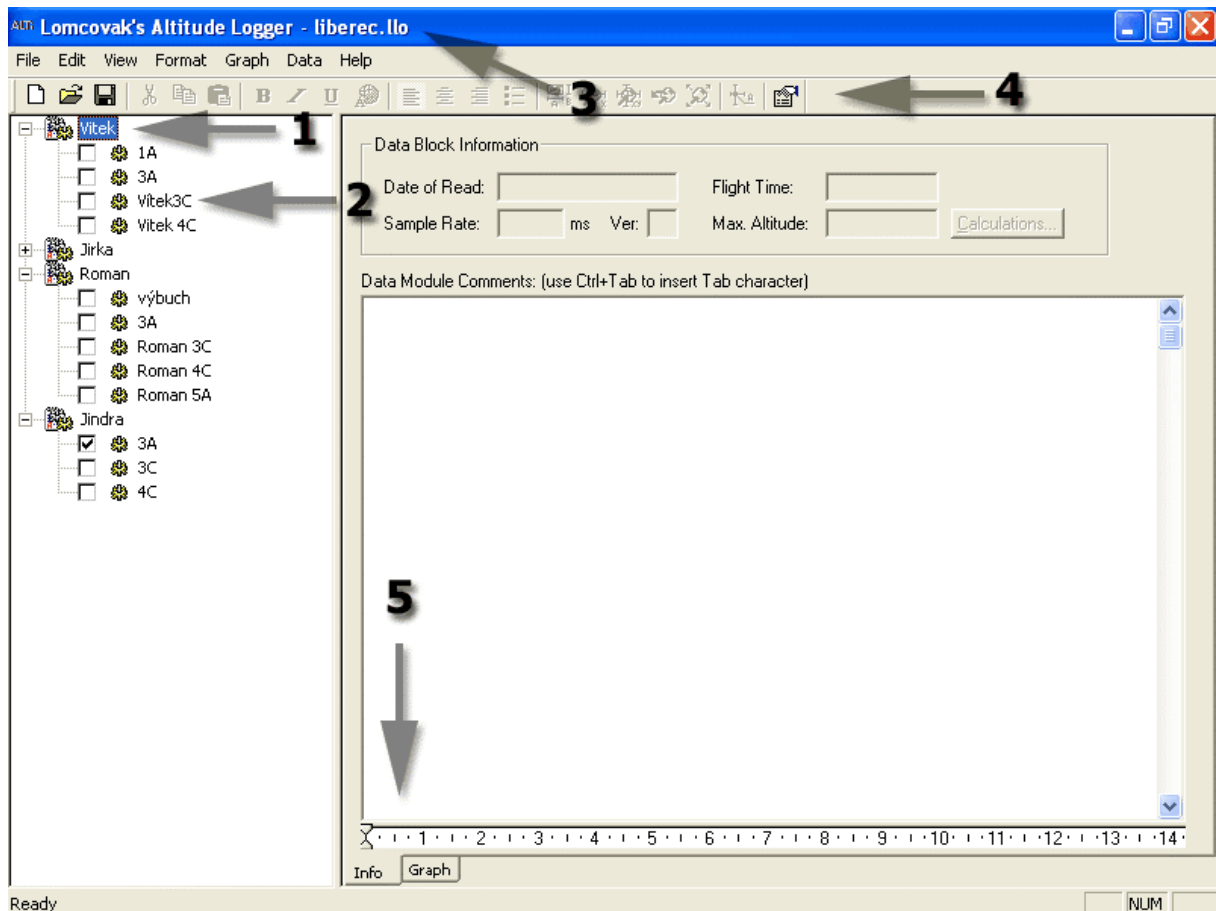

Picture 1

Picture 2 explanation

Always be carefull and watch what's selected or checked in left working area. As you see on picture I selected Vitek 1A (it has blue background). Also is checked Vitek 3A and Jindra 3A, both are just checked, NOT selected! See **1** and **2**. Ok, Vitek 1A is selected and in Data Block Information you can see some key data, see **4**. In button Calculations...you can always (even later on) change formula under which you want to calculate graph of altitude, see **3**. In Info space you can use some limited formatting capabilities using formatting icons or menu Format.

Picture 3 explanation

I changed view to tab Graph, see **1**. While there are checked Vitek 1A,3A and Jindra 3A, you see all logs in one working place. Just check any other flight and it will be immediatelly showed in window. There are interesting and important icons on top of window-toolbar. Icon **2** allows you to switch ON/OFF Data Measurement Mode, **3** allows you X-time axis zoom (click and drag), **4** is XY zoom (click and drag), **5** is undo last zooms (click), **6** is reset all zooms and be oriented if lost in zooming. **7** allows you to add annotations to any portion of graph. By default is your mouse movement followed by floating XY cross, see **9**. It can be changed in Graph, Data Cursor. Position of floating cross is showed in upper left corner of working area, see **9a**. You can also change Time axis from minutes to second by checking **10**.

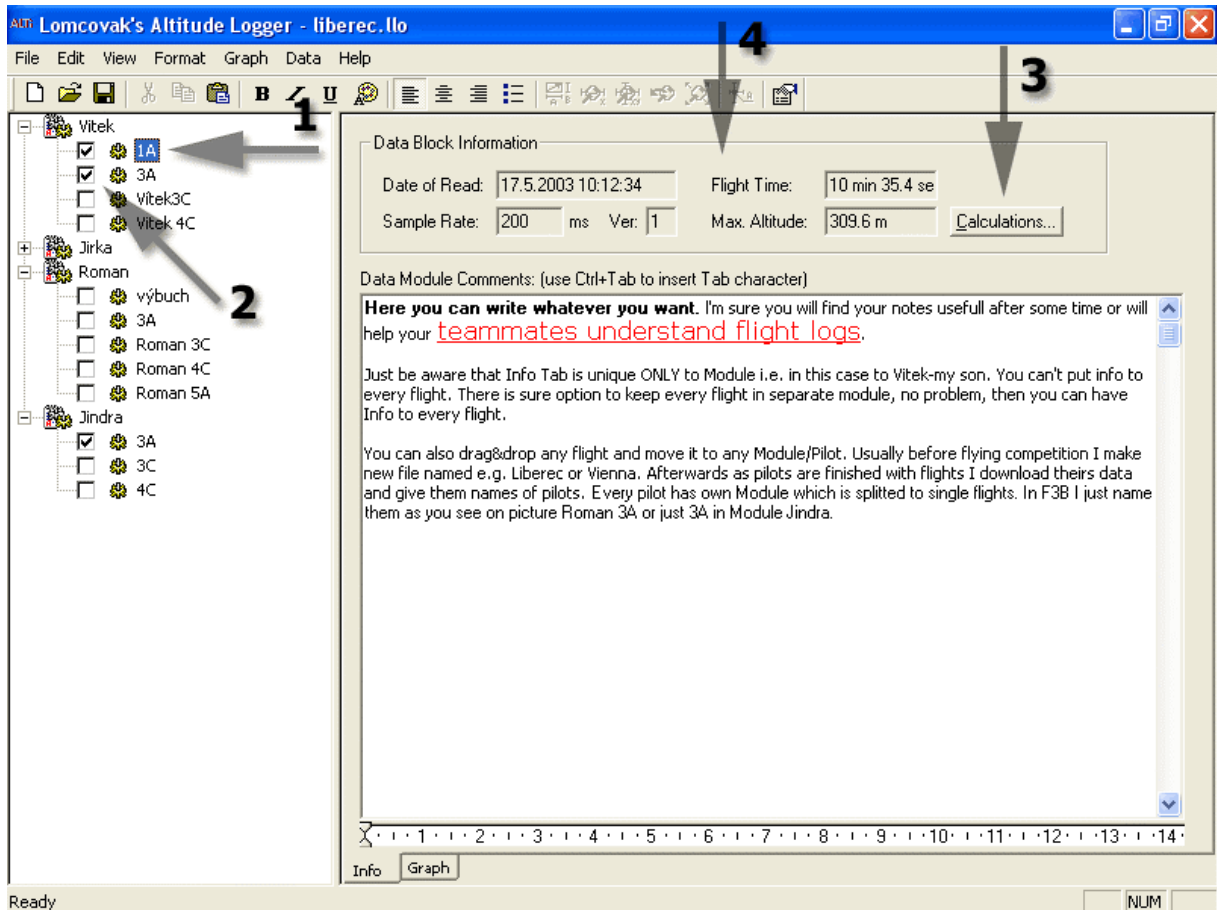

Picture 2

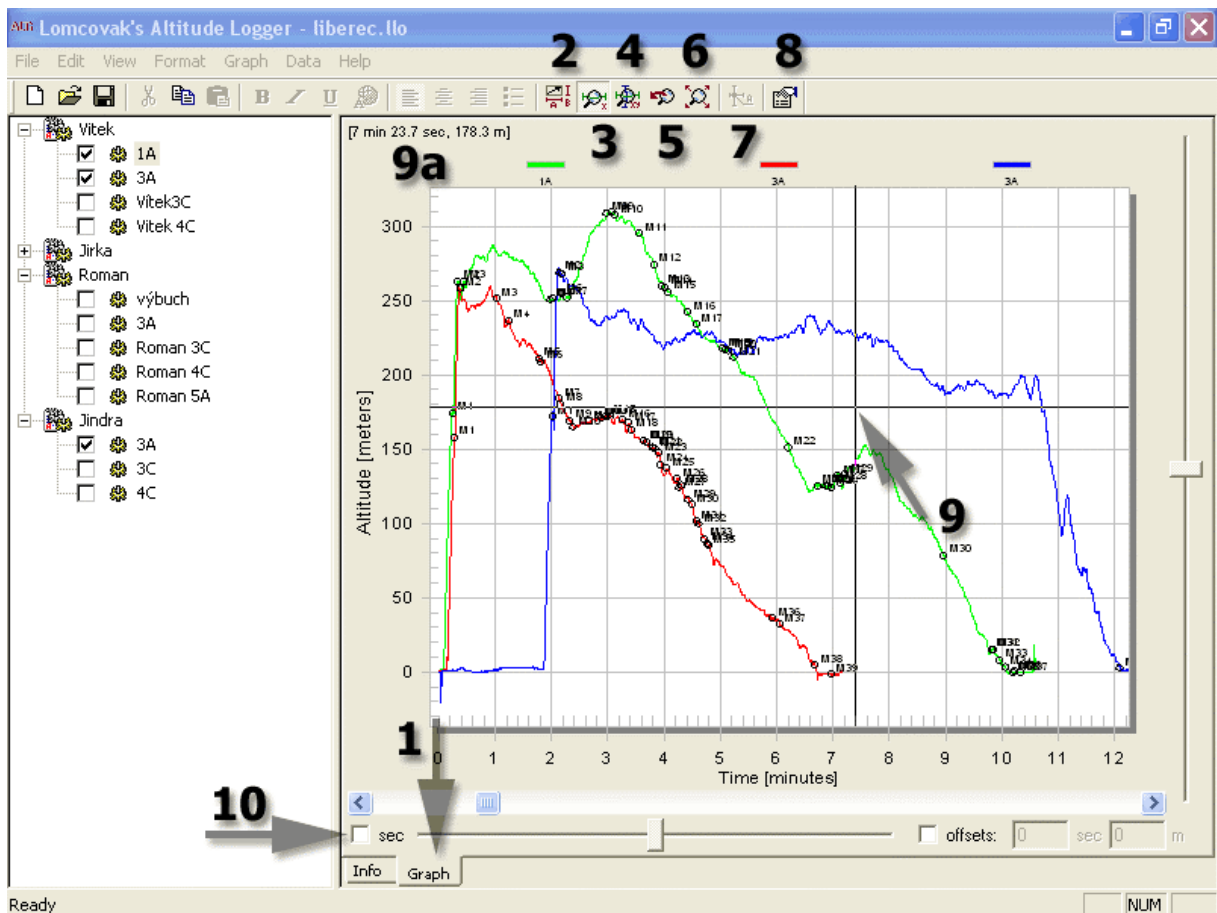

Picture 3

Picture 4 explanation

Fine, lets compare launch height of Vitek in first duration (1A) and Jindra in third duration (3A), see **1**. I will shift Vitek's flight 1A(green) to Jindra's 3A (red), see **3**. Select Vitek 1A and then click check box offsets, see **4**. Now shifting sliders **5** (red arrows) you can move Vitek's 1A to any point in working space. Usually I use only time slider. Also works, if slider is selected, with left/right keys on your keyboard. Time axis in sec is selected, see **2**.

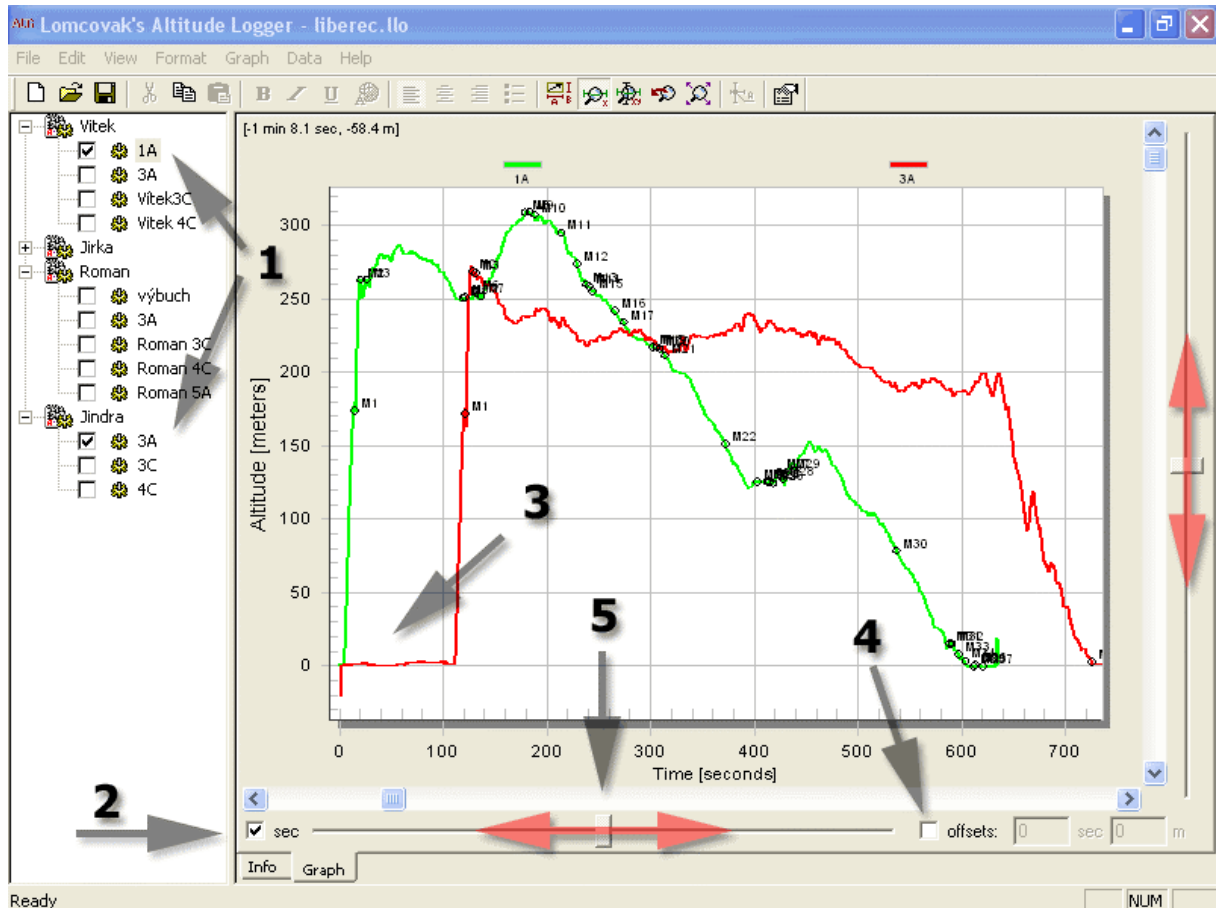

Picture 4

Picture 5 explanation

Using slider (after checking **1**) or even direct input of values in **2**, I aligned both graphs to common point on time axis **3**. Well it's on time axis somewhere nearby 100sec. Hmmm, I'd like to have it starting at 0sec...

Picture 6 explanation

...ok, just right click in point where you want to have time and height axis zero (0,0) and from menu choose Apply Offsets, see **2**. Sure, I made zooming before this step, just to zoom F3B launch phase from whole flight using icon **1** (click and drag).

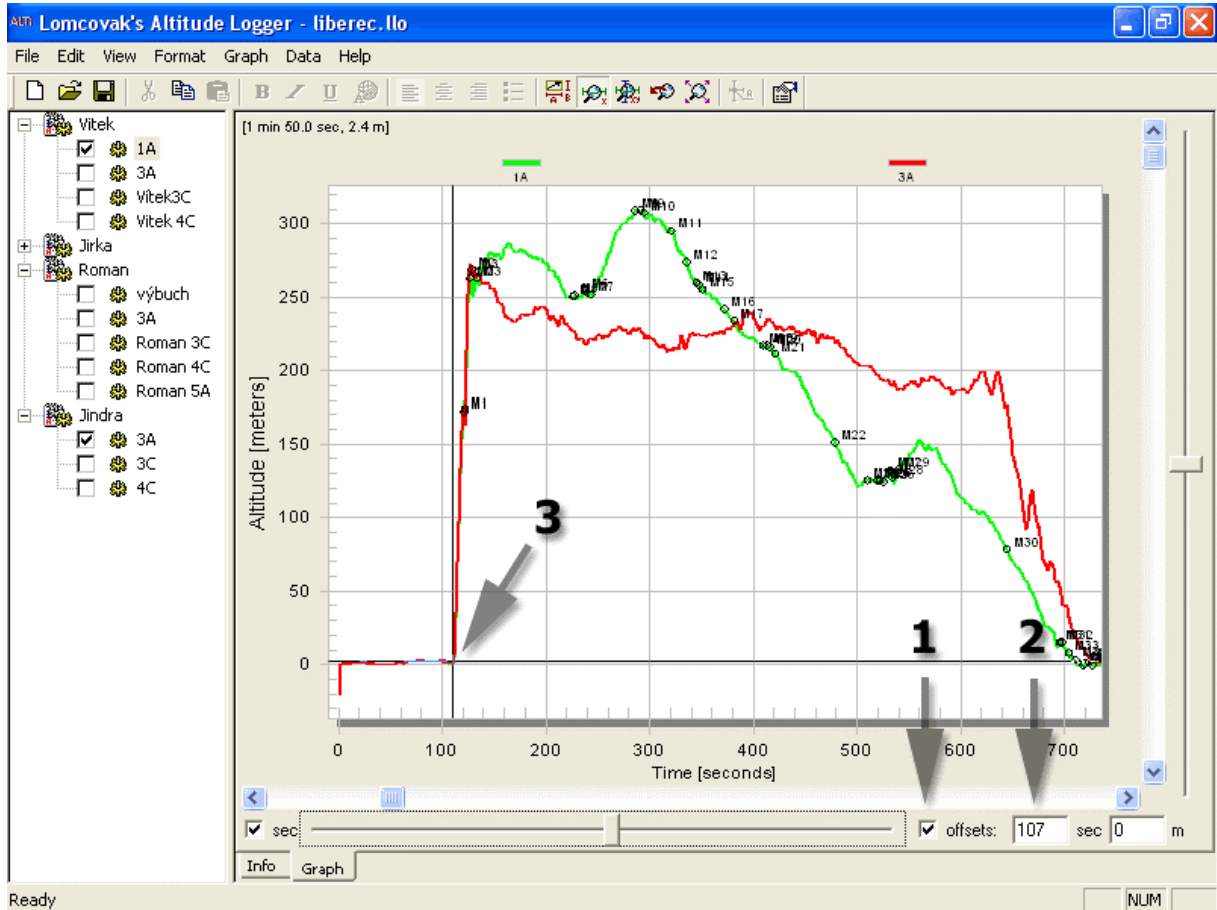

Picture 5

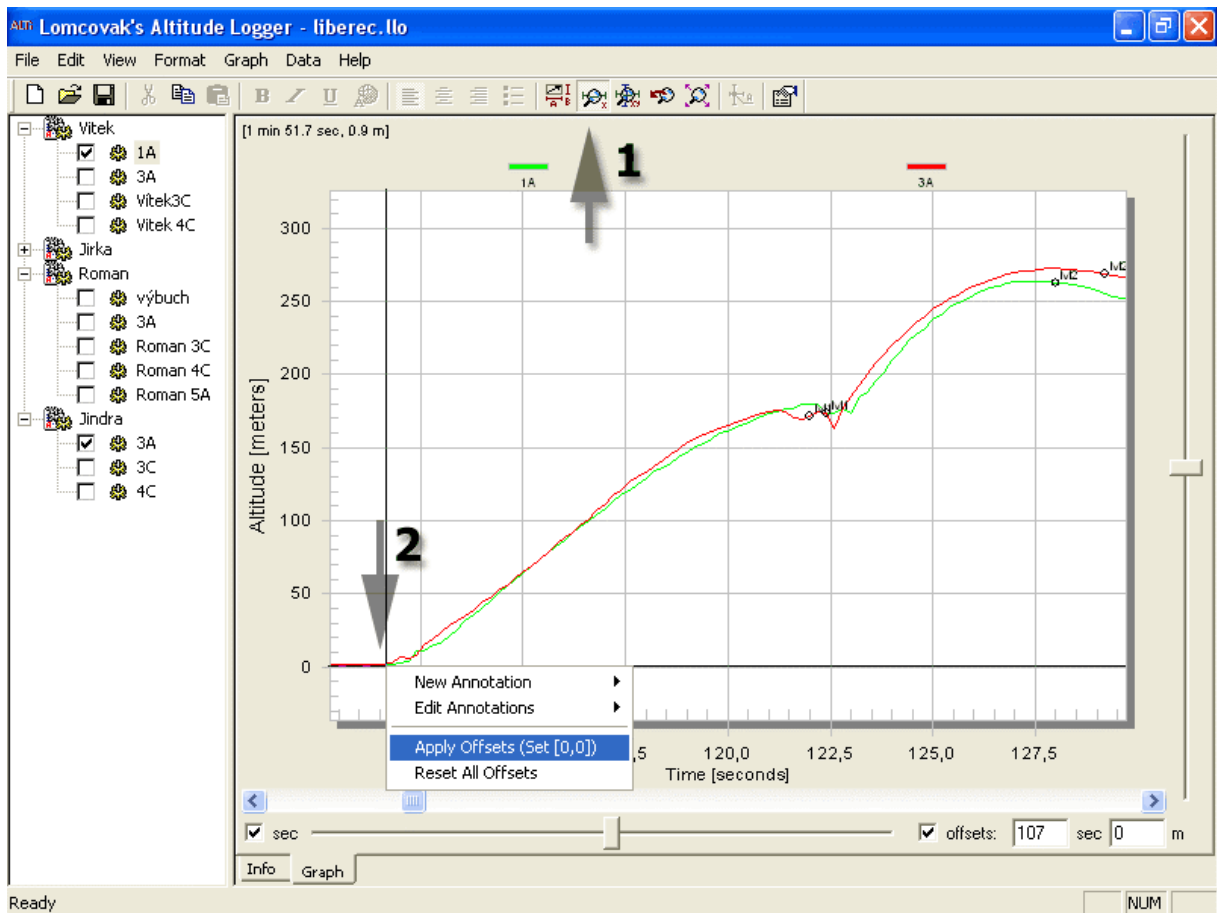

Picture 6

Picture 7 explanation

We have now initial part of F3B launch, aligned, beginning of time and altitude axis in requested point **1** and zoomed. Now click **2** and let's be in Data Measurement Mode. Now if you click (keep pressed left mouse button) and drag in graph window, in bottom left part of working space will popup Data Measurement window. Just click-you will get first point, drag and release, you will get second point. Points are marked my red cross **6**. Result you can see in above mentioned window, see **3** and **4**. You can also define custom functions, clicking **5**. In this case it is Rate of Climb. Using **7** and **8** is evident, you will copy results of measurement either to Windows Clipboard or Info window...

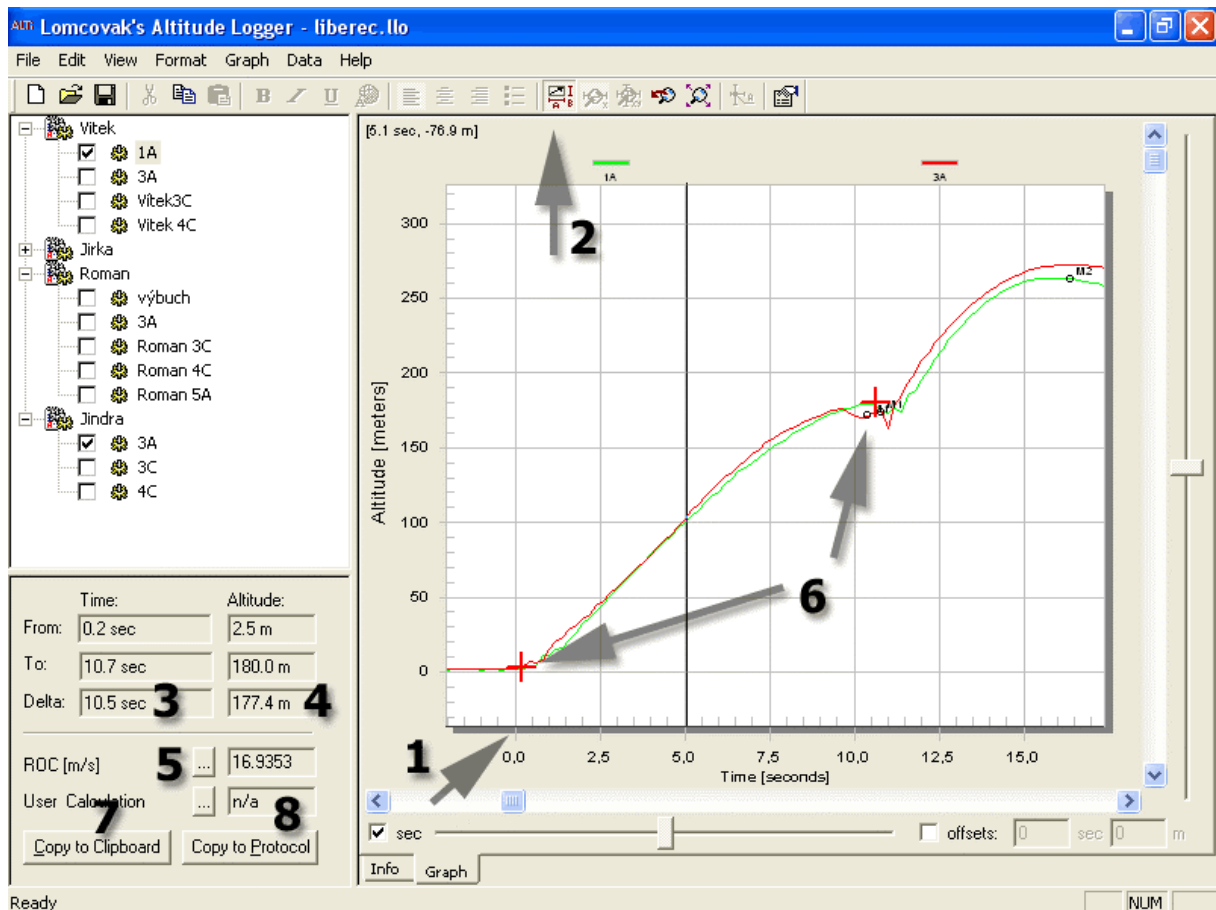

Picture 7

Picture 8 explanation

...all data are pasted to Info window, see **1**.

A2 Data Structure Definition

If you want to know data structure or to write your own software for A2 data analysis you will find Data Structure Definition on my website at <http://www.lomcovak.cz/a2/a2dsd.pdf>.

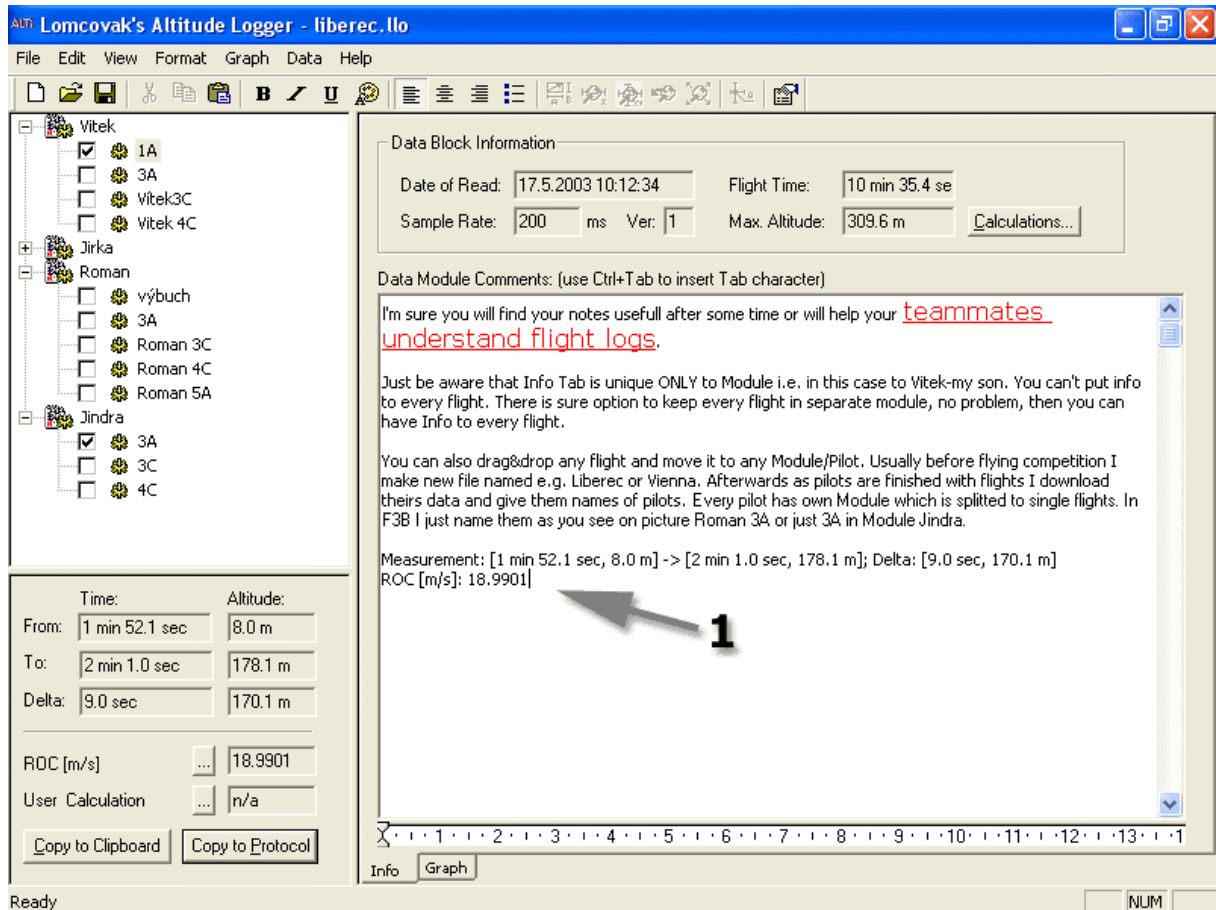

Picture 8

HW Hack

If you want to activate second set of longer sampling rates follow these instructions and watch picture 9.

- 2-nd set gives you 0.2sec (28min), 1.0sec (2h:16min), 2.0 sec (4h:32min) and 6.0sec (19h:36min) sampling rates for A2 Standard version
- 2-nd set gives you 0.2sec(1h:52 min), 1.0sec (9h:4min), 2.0 (18h:8min) and 6.0sec (54h:30min) sampling rates for A2 BF version
- Using sharp scalpel open small window in shrink tube on red marked position
- Using solder bridge two soldering points (see picture)
- Cover window by tape

This hardware modification will not void your warranty. Anyhow don't repeat soldering on mentioned points several times, you can damage printed board circuit.

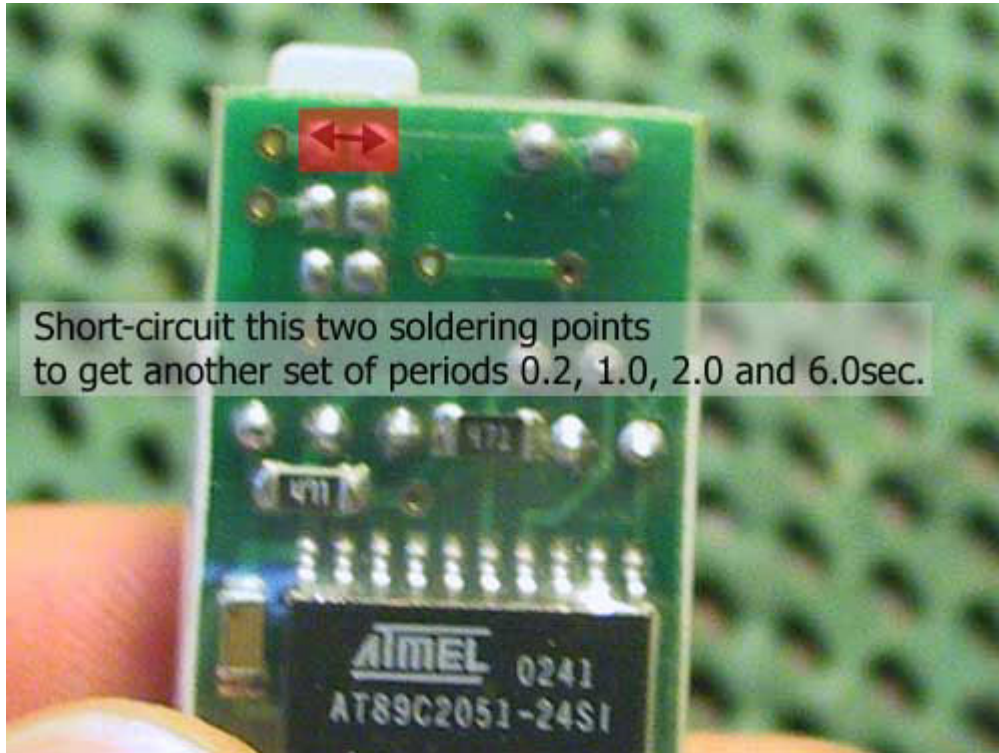

Picture 9

Price for Standard and BF version

Basic price for ALTI 2/LOLO2 STANDARD is 115EUR without any shipping and handling (10EUR WorldWide). What's included?

- Altitude logger
- RS232 interface cable
- licence for analysis software (please ask for software download link)

Basic price for ALTI 2/LOLO2 BF is 140EUR without any shipping and handling (10EUR WorldWide). BF version is same as STANDARD but it has four times more memory i.e. provides you with four times longer logs. What's included?

- Altitude logger
- RS232 interface cable
- licence for analysis software (please ask for software download link)

There are other extras available

- Cable with with remote LED. Allows you to control logger status outside of model. Price is 10EUR
- Cable with button allows you to input Markers in standalone application, e.g. during your trekking, biking, etc. Also allows you to clear A2 memory. Price is 10EUR
- Extra interface cable. You can let your price included cable permanently connected at home PC and carry this extra one to airfield. Price 20EUR
- USB/RS 232 convertor cable. Allows you to connect any LOLO or LOLO2/ALTI2 to USB only PC. There are drivers for Win 98, Me, 2000, XP, Linux, MacOS 9 and MacOS X included. Price 40 EUR
- If you are owner of LOLO, LOLO RACE or ALTI, ALTI RACE you can buy analysis software licence. Price is 25EUR. Software licence price is included in A2 package.

WorldWide Dealers

- **Germany** Thommy Seidel, Thommy Modelbau at <http://www.thommys.com/>
- **UK** Greg Taylor, Soarhigh at <http://www.soarhigh.co.uk/>
- **USA** Sheldon Smith, YNT Design at <http://www.yntdesign.com/>
- **Japan** Takeshi Asahara, RC saiplain at <http://rc-sailplane.com/>

You can buy A2/L2 direct from me (info@lomcovak.cz), but I recommend you to contact your local dealer first.

Warranty

- The ALTi2 is warranted to be free from manufacturing and material defects for a period of 24 months from the original date of purchase.
- Improper installation or damage to the external plastic cover will void your warranty
- Unauthorized repairs or modifications will void your warranty

Questions&Answers

Q Does the unit keep its recorded data when A2 is powered OFF?

A Yes! Until you will clear memory. However you can't clear memory seletively i.e. only some logs. You can clear only whole memory.

Q Can you change the sampling rate without loosing the data? For example, could you do a flight at the 0.1 second rate, then change to the 0.5 second rate and do another flight, and then download the data from both flights at the end?

A Yes! No problem, just sampling rate must be switched over (using DIP switch) when A2 is OFF.

Q In LOLO/LOLO RACE there were only 10 ON/OFF blocks. Is there any limit in A2/L2?

A No! There is no blocks-flights (ON/OFF) limit in A2/L2.

Q What kind of interface on PC do I need ?

A You need RS 232 interface e.g. serial port (also known as mouse port; COM1-5). If your PC has ONLY USB port you can buy USB/RS232 adapter. There are many on the market, be carefull many of them doesn't work properly. You can buy from me USB/RS232 adapter wihich 100% works with A2. Sure it works also with other RS232 devices.

Q A2 LED is just off, no blinking. Power is ON. It doesn't log. What 's wrong with my A2?

A Your A2 memory is full. Clear it!

Q It's possible to adjust the sensibility? When I power on my A2 just on the table values oscillate around 0 or even during time is drifting to bigger +/- altitudes.

A Used technology A/D converter etc. is price/performance compromise. If you want to measure altitude with 0.5m resolution (and better), always there will be some noise. Its like water surface, looks smooth but never is totally smooth. You should be aware A2 is VERY sensitive atmosphere/altitude converter, if there is weather change, sure air pressure is changing (especially during longer timed logs), when you have A2 on the table and your wife will smash with doors (So silly thing, so expensive!! :) you will see it in altitude log. To eliminate all these effects would increase complexity, size and price, sure.

Q It's possible to calibrate my A2 precisely?

A Yes and No. Every A2 is calibrated to fit ordinary application precision. We tested some A2 pieces in Czech Airlines laboratories, in pressure chamber for full size airplanes altimeters. Testing staff was amazed by precision of this tiny device! On the other hand there was still room to modify pressure/altitude formula to reach exceptional precision. Its clear I can't make such calibration on every piece, its extremely expensive. Anyhow you can modify pressure/altitude formula to reach requested precision on your own. Its opened system.

Sales&Service

Dipl.Ing.Roman Vojtech
U Studanky 31
170 00 Prague7
Czech Republic
EUROPE

e-mail: info@lomcovak.cz
web: www.lomcovak.cz

7-th, November 2003, ver. 1.1 ENG